

Bowserwasher (Petrol)

This highly versatile unit allows for cleaning or drain maintenance to be carried out, even in the most remote of locations. It carries 940 Litres of water and with built in chemical & anti-freeze tanks on a single axle trailer. A Max Gross weight of just 1500KG means it can be towed behind most commercial vehicles. As well as cleaning it can also be used for drain jetting, machinery & plant washing, wheel washing, concrete preparation and general site cleaning.

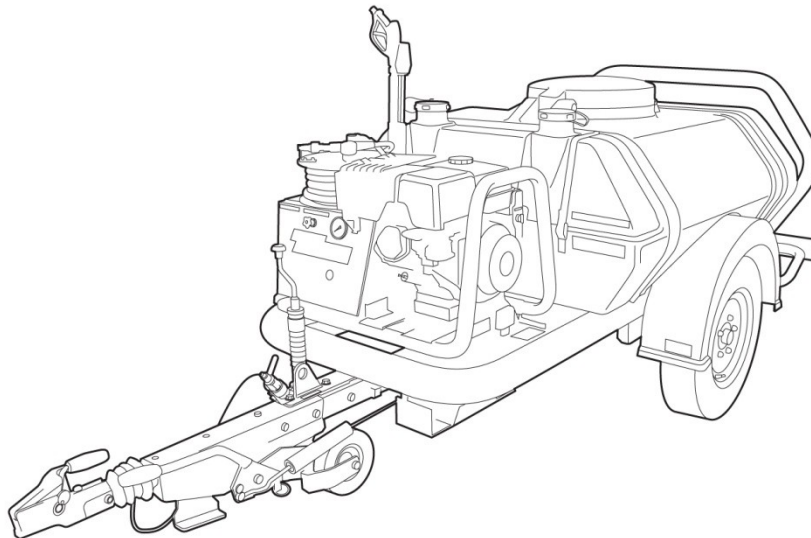

These instructions include:

- Operation
- Day to day maintenance
- Transport

Guidance for use:

- Appropriate barrier where required
- Appropriate PPE

Towing:

- The towing vehicle must be suitable to tow this weight
- Check to make sure your driver's licence entitles you to tow this machine
- The max speed on the motorway is 60mph

Operational Safety and Care:

- Anybody using this machine should have adequate training.
- Appropriate PPE should be worn at all times
- Anybody using this machine should be over 18 as misuse of high pressure water can be dangerous
- Follow all instructions and labels on the machine for safe operation
- Do not point the lance at persons or animals, even when the machine is off as there may still be residual pressure
- If you are unsure of any of these instructions please refer to Operators Manual for the machine
- Work only in safe areas
- The machine is not a toy
- Read and follow the instructions carefully
- Do not use high pressure on delicate surfaces.
- Always test surface to be cleaned

BRENDON POWERWASHERS

BUILT TO LAST ... DESIGNED TO PERFORM

Units 2, Hillsmoor, Sandys Moor, Wiveliscombe, Taunton, Somerset, England TA4 2TU
Telephone: (+44) 01984 624500 Fax: (+44) 01984 624501

www.powerwashers.co.uk

Bowserwasher (Petrol)

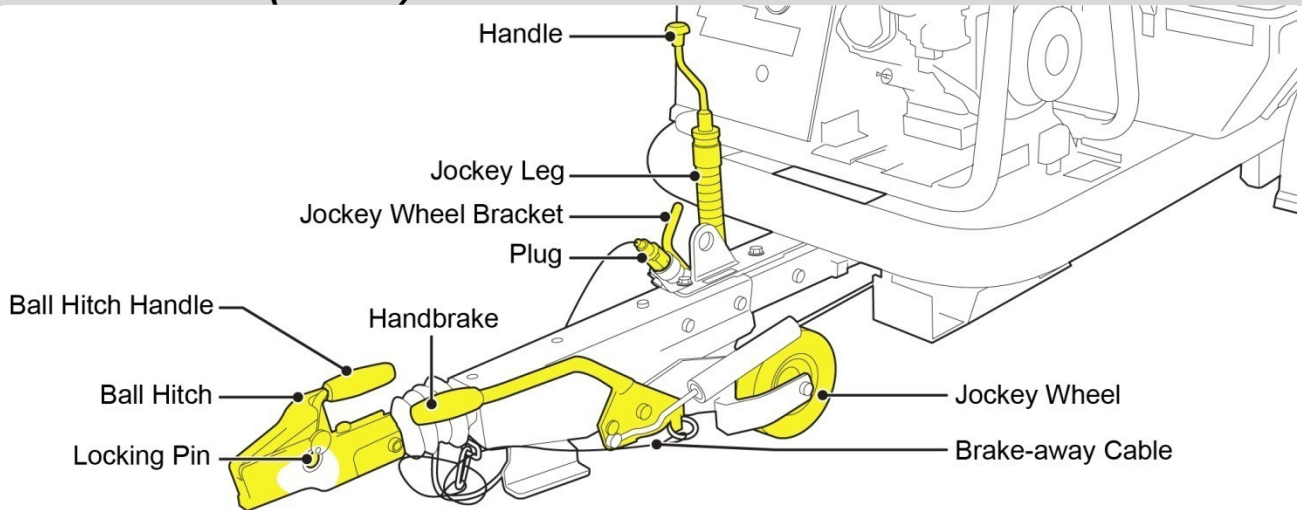

Towing

Warning! The towing vehicle must be approved to tow a weight of MAM 1500kg
Warning! Check your driver's licence entitles you to tow a trailer with a MAM of 1500kg.

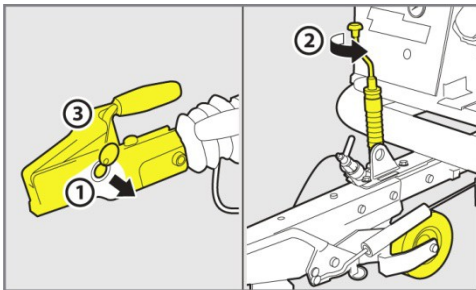

Preparation

1. Remove the security lock
2. Use the jockey wheel to raise the hitch
3. Position the hitch over the towing ball

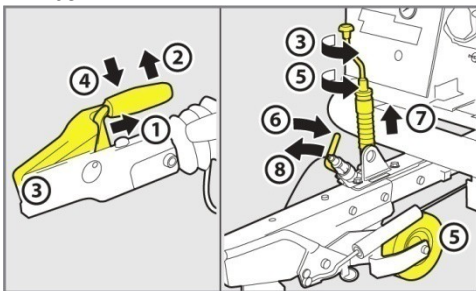

Hitching

1. Push the safety catch to release the handle
2. Raise the handle

3. Lower the hitch onto the towing ball using the jockey wheel
4. Release the handle
5. Continue winding the jockey wheel until it is fully raised
6. Release the jockey wheel bracket
7. Raise the jockey wheel up
8. Tighten the jockey wheel bracket

Connecting

1. Put the plug in the socket
2. Hook the brake-away cable onto the towing vehicle
- Attention!** Do not loop brake cable around the towing ball
3. Check all the lights are working
4. Release the handbrake ready for towing

Reversing

Tip! The over run brake works automatically when reversing!

1. Check if you have enough space when reversing.

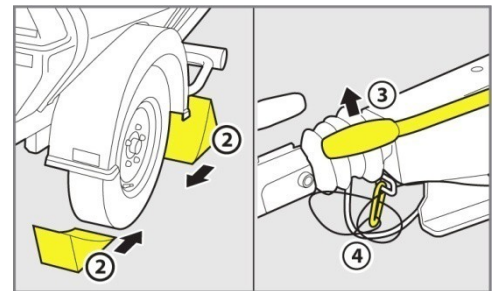

Unhitching

2. Put the machine on flat ground
3. Put chocks in front and rear of wheels (Not UK Spec)
4. Pull hand brake
5. Release safety brake cable.
6. Pull plug out of socket.

Bowserwasher (Petrol)

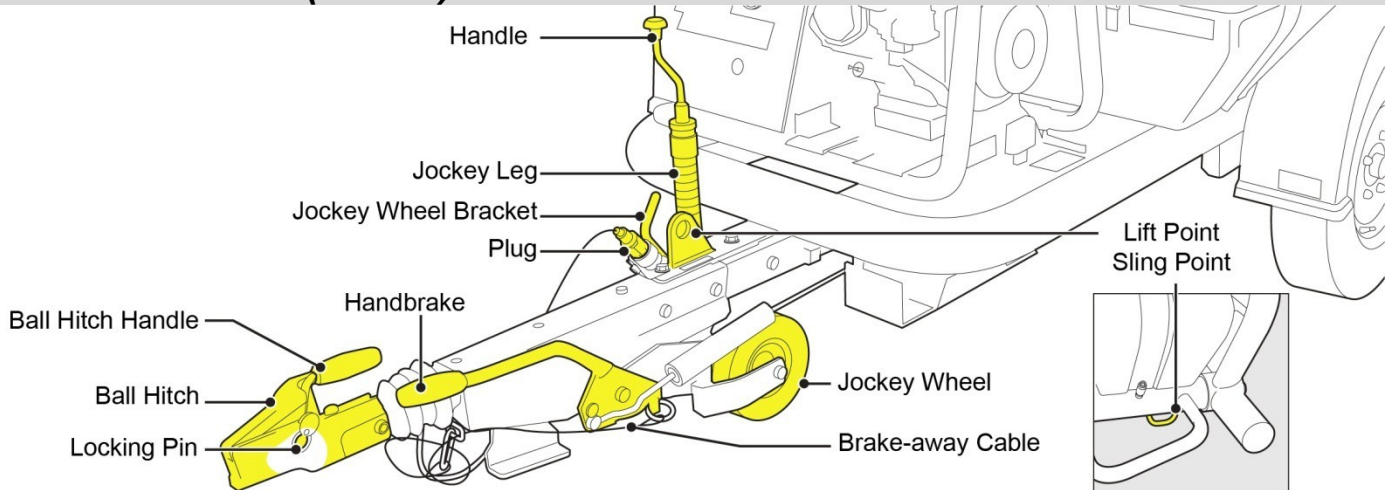

Towing (cont.)

Release/Park

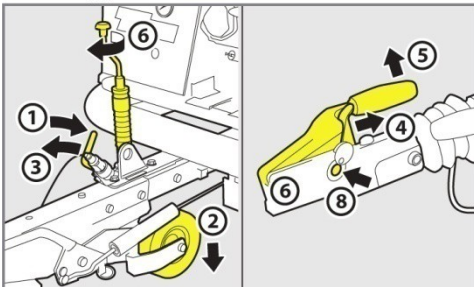

Attention! When parking the machine on a slope make sure the hitch is facing downhill!

1. Release the jockey wheel bracket
2. Lower the jockey wheel
3. Tighten the jockey wheel bracket
4. Push the safety catch to release the handle
5. Pull the handle up
6. Use the jockey wheel to raise the hitch
7. Unhook the safety brake cable
8. Replace the lock
9. Pull out the plug.
10. Move the machine and adjust the jockey wheel until the unit is level with the road.

Lifting the machine

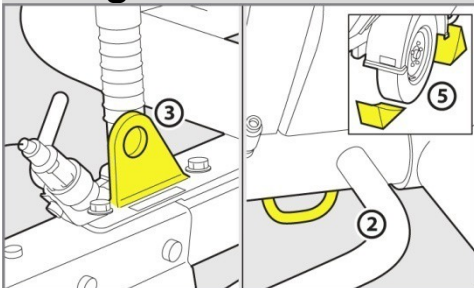

Warning! Use only approved lifting slings

1. Check your lifting slings for signs or damage or wear
2. Thread the long sling through the two sling points on the rear of the chassis
3. Attach the short sling to the front lift point using an adequately rated 'D' shackle
4. Carefully lift the machine and lowered it into the desired position
5. Chock the wheels if the machine is being placed at height (Not UK Spec)

BRENDON POWERWASHERS

BUILT TO LAST ... DESIGNED TO PERFORM

Units 2, Hillsmoor, Sandys Moor, Wiveliscombe, Taunton, Somerset, England TA4 2TU
Telephone: (+44) 01984 624500 Fax: (+44) 01984 624501

www.powerwashers.co.uk

Bowserwasher (Petrol)



Starter control box

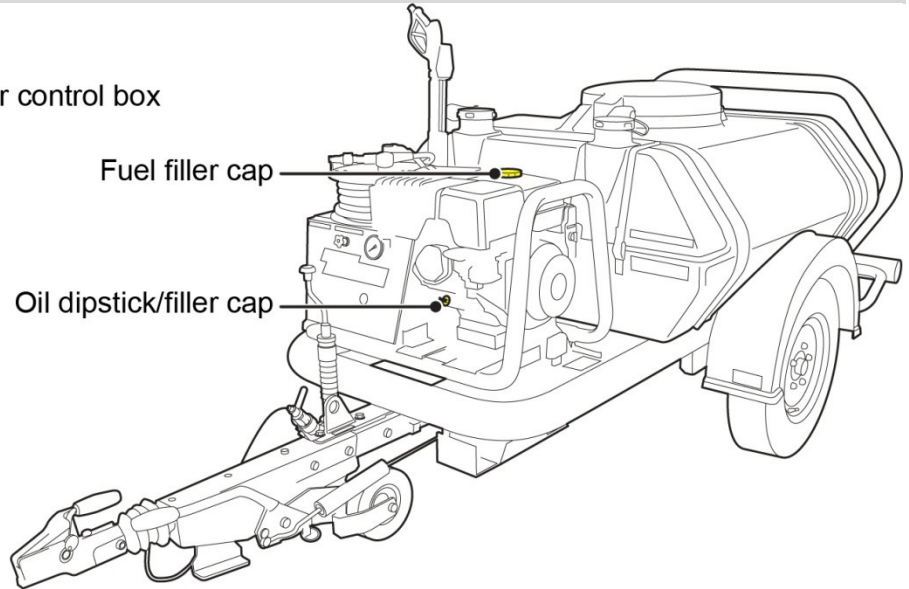

Fuel filler cap

Oil dipstick/filler cap

Before use:

General condition

1. Check for any damage, wear or leaks on all the hose and fittings

Checking the fuel level

Warning! Make sure area is well ventilated

Warning! Keep fuel away from open flames and heat sources

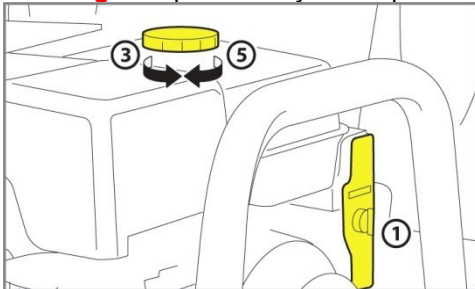

1. Switch off the engine
2. Clean area around the filling cap
3. Unscrew the filling cap
4. Check fuel level, add if necessary
5. Screw fuel cap back on
6. Cleanup any spilt fuel

Note: Tank capacity 6.5 L

Adding Engine Oil

Attention! Only use the approved oil SAE 10W40

1. Clean area of the oil fill cap
2. Unscrew fill cap and top up
3. Fit the filler cap
4. Run the engine for approx. 1 minute and recheck the oil level

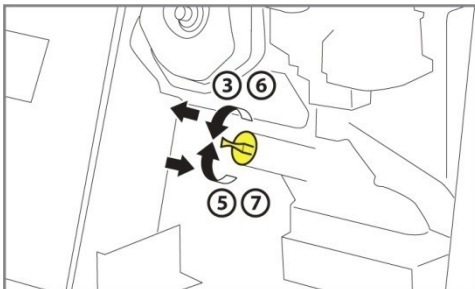

Engine Oil

Attention! The engine must be switched off.

Warning! Oil level will not read correctly when the engine is warm

1. Put the machine on level ground.
2. Clean area around the dipstick.
3. Unscrew dipstick and pull it out
4. Clean dipstick.
5. Replace dipstick and tighten.
6. Unscrew dipstick pull it out and check oil level
7. The oil level should be between the MIN-MAX
8. Put the dipstick back

BRENDON POWERWASHERS

BUILT TO LAST ... DESIGNED TO PERFORM

Units 2, Hillsmoor, Sandys Moor, Wiveliscombe, Taunton, Somerset, England TA4 2TU
Telephone: (+44) 01984 624500 Fax: (+44) 01984 624501

www.powerwashers.co.uk

Bowserwasher (Petrol)

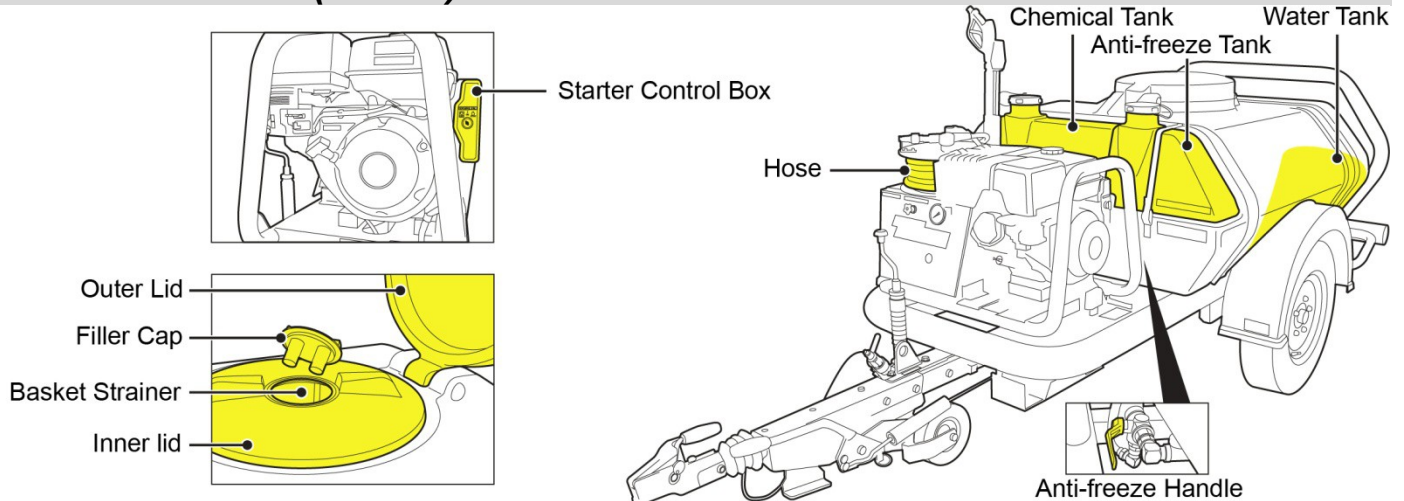

Preparation Use (Cont.)

Change lance

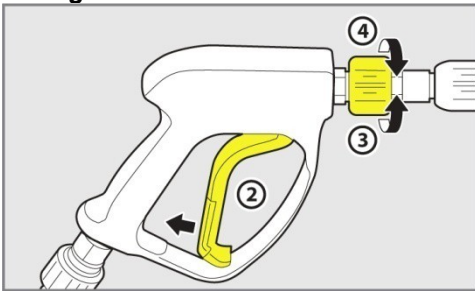

- Warning!** Please be careful to avoid any dirty or debris entering
1. Lower the throttle to idle
 2. Engage red locking catch on the trigger
 3. Unscrew the coupling the lance
 4. Fit the coupling hand tight
- Tip!** Use Turbo lance with max pressure for quicker and more aggressive cleaning.

Anti-freezing

To Anti-freeze:

1. Disconnect the lance
2. Lift the red anti-freeze handle to the vertical position
3. Start the machine on idle
4. Once you see anti-freeze coming out of the hose stop the machine
5. Return the red handle to horizontal position

Adding Chemicals

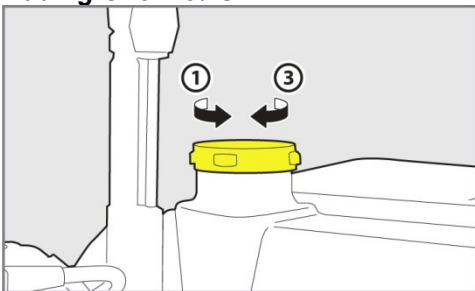

- Attention!** Only use approved chemicals
1. Unscrew tank cap
 2. Fill the tank with the chemicals
 3. Fit the Cap back on.

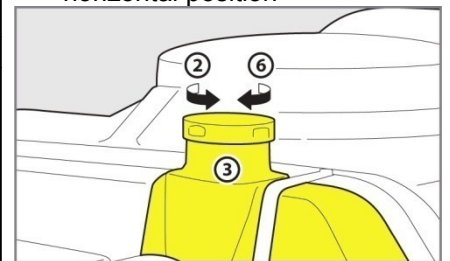

Fill Water tank

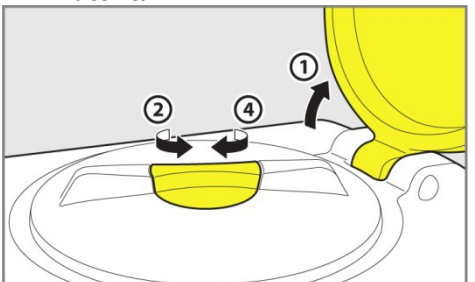

- Warning!** Fill tank only with water
1. Open lid
 2. Unscrew tank cap
 3. Fill with water
 4. Fit the tank Cap and closed the lid

Before Using:

1. Disconnect the lance
2. Unscrew the anti-freeze cap
3. Put the end of the hose into the anti-freeze tank
4. Start the machine on idle
5. Once you see the water running clear stop the machine
6. Screw the cap back on

BRENDON POWERWASHERS

BUILT TO LAST ... DESIGNED TO PERFORM

Units 2, Hillsmoor, Sandys Moor, Wiveliscombe, Taunton, Somerset, England TA4 2TU
Telephone: (+44) 01984 624500 Fax: (+44) 01984 624501

www.powerwashers.co.uk

Bowserwasher (Petrol)

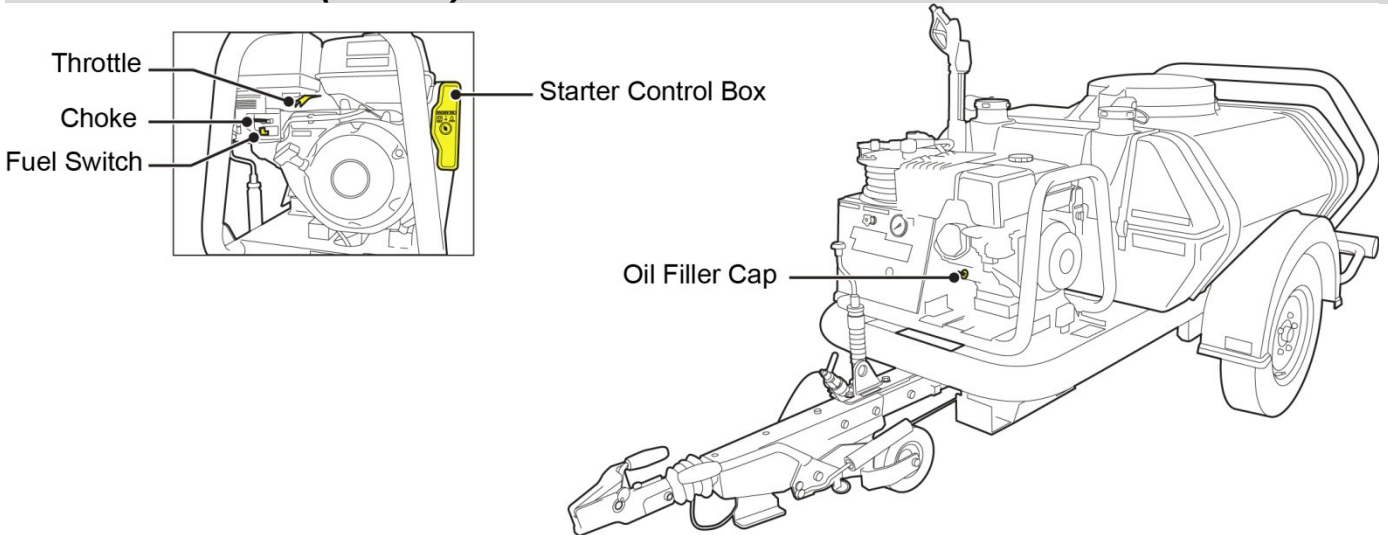

Operating

Starting

Warning! Only use machine in a well ventilated area

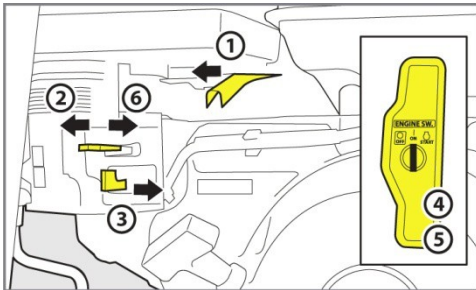

1. Move the throttle lever to the left
2. Move the choke lever totally to the left.
Attention! Not necessary when you have a higher outside temperature or when the engine is warm!
3. Move the fuel lever to the right (open)
4. Turn the starter switch "ON"
5. Turn the starter switch to "START" allowing unit to start
Attention! Amp Light will show
6. Move the choke lever to the right as machine becomes warmer

Automatic oil alert

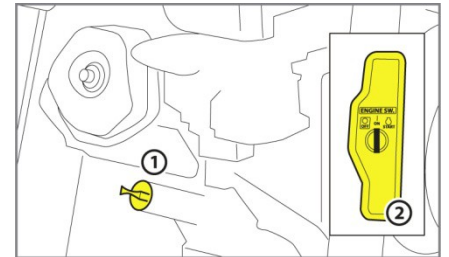

Attention! This engine is fitted with a low oil alert system that will shut the engine off when oil is low

1. Check oil level and top up
2. Start Engine

Stopping the Engine

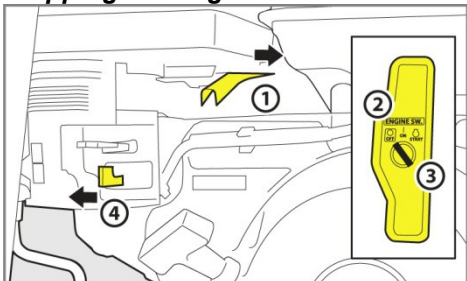

1. Push your throttle to the right
2. Put starter switch to "OFF"
3. Remove ignition key
Attention! Do not leave the machine unattended whilst key is in ignition!
4. Move the fuel switch fully to the off position (left)

BRENDON POWERWASHERS

BUILT TO LAST ... DESIGNED TO PERFORM

Units 2, Hillsmoor, Sandys Moor, Wiveliscombe, Taunton, Somerset, England TA4 2TU
Telephone: (+44) 01984 624500 Fax: (+44) 01984 624501

www.powerwashers.co.uk

Bowserwasher (Petrol)

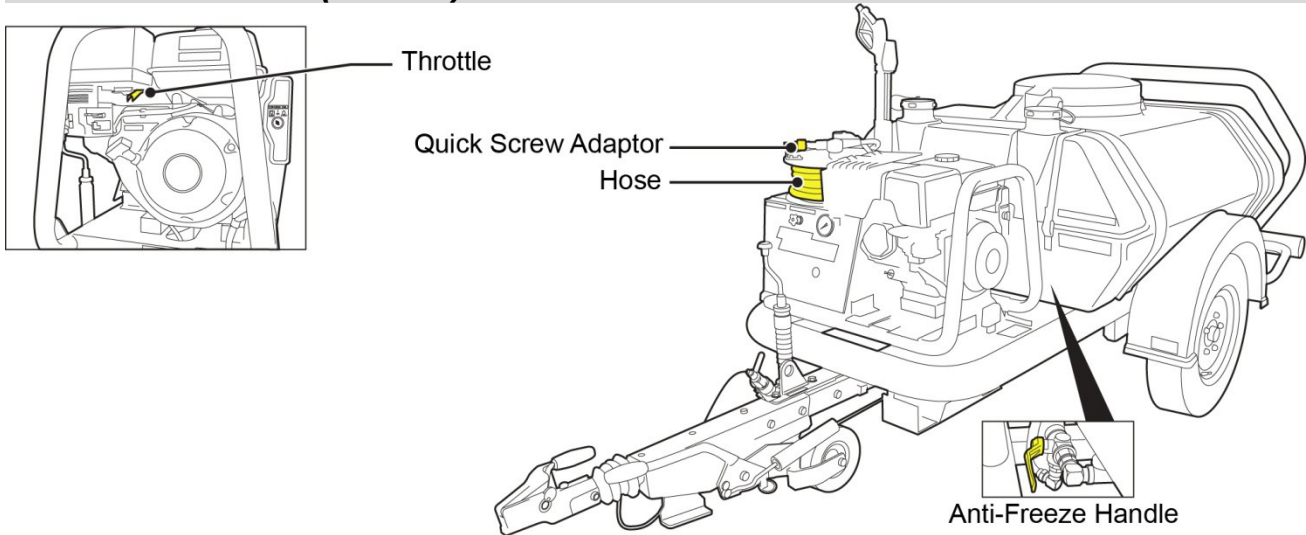

Operating (cont.)

Working with the machine

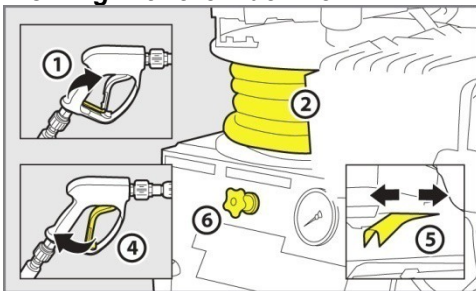

1. Pull red safety clip up.
2. Pull hose to roll off.
3. Point lance to cleaning area
Warning! High Pressure water is dangerous! Never point the lance at a person or animal
4. Pull the trigger
5. Set the pressure by adjusting the engine revs
6. Adjust chemical valve to the required volume of chemical for the job
7. Keep lance at a minimum of 5-10cm from object and move it slowly

After Use

Turning off the machine



1. Shut the throttle down to stop the engine
2. Turn the key to the off position
3. Point the lance away from you and pull the trigger to release any residual pressure
4. Remove the gun and place in the holder
5. Wind the hose onto the reel

Anti freeze protection

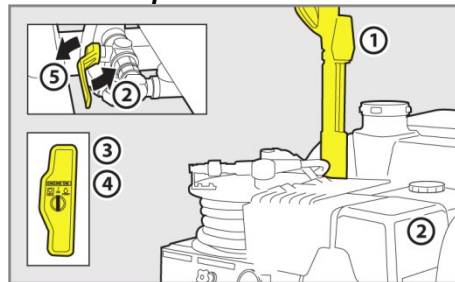

1. Disconnect the lance
2. Lift the red anti-freeze handle to the vertical position
3. Start the machine on idle
4. Once you see anti-freeze coming out of the hose stop the machine
5. Return the red handle to the horizontal position

Ready for transport

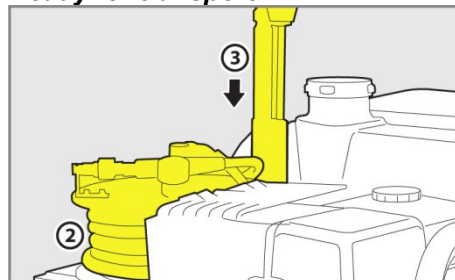

1. Clean the machine with low pressure (max. 6 Bar)
2. Wind the hose back onto the reel
3. Take lance off and put in holder
4. Put the machine ready for transport in a safe area.